

A study on the tribological behaviour of ultra-high molecular weight polyethylene (UHMWPE) coated with a Ni–P layer

R. ZHANG*

Dept. of Mechanical Engineering, Tsinghua University, Beijing, Peoples Republic of China

QI SONG

Research Institute of Transculture of Euromat, Paris, France

R. WALTER, A. M. HÄGER

Institute of Composite Materials, University of Kaiserslautern, 67663 Kaiserslautern, Germany

The tribological behaviour of ultra-high molecular weight polyethylene (UHMWPE) has been investigated using friction and wear tests at room temperature ($\sim 25^\circ\text{C}$) and also at a low temperature ($\sim -20^\circ\text{C}$) in air, vacuum or CO_2 saturated vapour for UHMWPE rubbing against itself and also against a steel counterpart. A sticking phenomenon took place in saturated CO_2 vapour at low temperature ($\sim -20^\circ\text{C}$), which was produced by severe adhesion between the UHMWPE polymer rubbing pair. The sticking phenomenon was prevented by a Ni–P coating deposited on the surface of the UHMWPE by means of high-speed electro-plating. Non-continuous transfer films of UHMWPE on the Ni–P surface layer and the steel surface were observed by scanning electron microscopy (SEM) and transmission electron microscopy (TEM). The studied coating has a solid lubrication character, so that its sliding friction coefficient μ and relative wear weight loss of the pin w_t decreased; the wear mechanism changed from adhesive wear to surface fatigue wear. It is concluded that the tribological behaviour of the UHMWPE polymer could be improved with a metallic coating, such as the Ni–P coating used in this study.

1. Introduction

As a thermoplastic, ultra high molecular weight polyethylene (UHMWPE) is characterized by a remarkable wear resistance, impact strength and a low temperature ductility that remains even at liquid-helium temperature. Bearings, in which the holder is made with UHMWPE, have good self-sealing and self-lubrication properties and can bear harder counterfacing parts without the loss of dimension stability. The tribological behaviour of UHMWPE, therefore, has been closely studied by scientists and engineers [1–10]. UHMWPE also slides against steel or other hard surfaces with very low wear coefficients and moderate friction coefficients. Studies on friction and wear between UHMWPE and a smooth hard counterface at low sliding speeds revealed that thin transfer films formed on the counterface [7, 10]. It was also found that the wear of UHMWPE is critically dependent on the temperature of the surface [5]. However, the amount of information available from these studies is not sufficient to judge the use of

UHMWPE bearings in space applications. In such applications the bearings work not only at moderate temperatures but also at cryogenic temperatures ($< -20^\circ\text{C}$) despite the fact that the temperature in the chamber of a man-made satellite is controlled. In addition the bearings usually work in a low or medium vacuum.

In this work, we have measured the sliding friction coefficients μ and the wear weight loss w_t of pins made of UHMWPE against UHMWPE and carbon steel discs at room temperature and low temperature ($\sim -20^\circ\text{C}$), in air and a vacuum of 6.67×10^{-3} Pa. In order to improve the tribological behaviour of the UHMWPE, a Ni–P coating was deposited onto the surface of the UHMWPE by means of high-speed electro-plating process. We have investigated the polymer transfer behaviour using a scanning electron microscope (SEM) and also a transmission electron microscope (TEM). Based on these observations and by comparison of the different rubbing pairs, the wear mechanisms of UHMWPE are discussed.

* Visiting Professor at the Institute of Composite Materials, University of Kaiserslautern, 67663 Kaiserslautern, Germany.

2. Experimental procedure

2.1. Preparation of the UHMWPE

Samples of the UHMWPE were supplied by the Plastic Research Institute of Beijing, Peoples Republic of China. Its typical properties are: molecular weight $> 2 \times 10^6$; tensile strength 44 MPa, impact strength $> 90 \text{ kg} \cdot \text{cm cm}^{-2}$.

2.2. Preparation of the high-speed electro-plated Ni-P layer

The Ni-P high-speed electro-plated coating on the UHMWPE was made by Tsinghua University, Peoples Republic of China. First, the surface of the UHMWPE was mechanically and chemically roughened then a thin Cu back-layer (10–20 μm) was deposited onto it. Finally, a Ni-5%P coating (0.15–0.20 mm) was deposited onto the Cu back-layer. The Ni-P layer was polished before the friction and wear tests. This procedure was described in detail in reference [11].

The coating technology of the Ni-P electro-plating on the UHMWPE is as follows:

1. Chemical plating Cu back-layer:

(1) Formulation

(a) Roughening liquid:

$\text{K}_2\text{Cr}_7\text{O}_7$	20–40 g l^{-1}
H_2SO_4 (concentrated)	850–950 g l^{-1}
H_2O	50–70 g l^{-1}
Temperature	50–70 $^\circ\text{C}$

(b) Sensitizing liquid:

SnCl_2	10–20 g l^{-1}
HCl	40 ml l^{-1}
Sn pellets	some
Temperature	15–30 $^\circ\text{C}$
pH	< 1

(c) Activation liquid:

AgNO_3	9–30 g l^{-1}
NH_4OH	20–100 ml l^{-1}
Temperature	18–20 $^\circ\text{C}$

(d) Reducing liquid:

37% HCHO : H_2O	1:9
Temperature	18–25 $^\circ\text{C}$

(e) Chemical Cu-plating liquid:

Cu salt	10 g l^{-1}
$\text{NaKC}_4\text{H}_4\text{O}_6 \cdot 4\text{H}_2\text{O}$	40 g l^{-1}
NaOH	8 g l^{-1}
$\text{NiCl}_2 \cdot 6\text{H}_2\text{O}$	1 g l^{-1}
Formaldehyde (reducing agent)	15 ml l^{-1}
Na_2CO_3	2 g l^{-1}
Temperature	15–25 $^\circ\text{C}$
pH	12 (alkaline)

(2) Procedure

- Mechanical roughening sand paper
- Chemical roughening 10 s
- Rinse with water immerse in the sensitizing liquid 5 s
- Rinse with water immerse in the activation liquid 30 s
- Rinse with water immerse in the reducing liquid 5 s
- plate Cu directly

2. High speed electro-plating of the Ni-P layer

The high speed electro-plating method is adopted to plate Ni-P since the UHMWPE disc which is plated with Cu is now conducting, the procedure is as follows:

(a) Purification treatment

Rinse the Cu-plating disc purified by NaOH (for neutralizing the protons)

(b) Activation treatment (can be omitted)

No. 3 activation liquid some (light green, pH = 4, specific conductance $2.1 \times 10^{-3} \mu\Omega^{-1} \text{cm}^{-1}$, freezing point -9°C , storage long)

$\text{Na}_3\text{C}_6\text{H}_6\text{O}_7 \cdot 2\text{H}_2\text{O}$	141 g l^{-1}
$\text{H}_3\text{C}_6\text{H}_6\text{O}_7 \cdot \text{H}_2\text{O}$	94 g l^{-1}
$\text{NiCl}_2 \cdot 6\text{H}_2\text{O}$	3.0 g l^{-1}
Working voltage	10–25 V
Relative velocity	0.1–0.15 m s^{-1}
Electronic polarity	reversing connection

(c) Electro-brush plating technology

Rinse the disc plated with the Cu back-layer The plating liquid formulated by Tsinghua University, Peoples Republic of China.

Comprising:

Major salts, sulfate, chloride;

Chelates, ammonium citrate, ammonium

oxalate, ammonium hydroxide, diethyl amine;

Supplementary salts, sodium sulfate;

Additives,

Buffer agent: boric acid;

Wetting agent (protecting fine pores): dodecane alkyl nickel sulfate;

Brightener agents: ammonium dithionate, formaldehyde.

An amorphous Ni-P coating could be deposited on to the surface of the UHMWPE. It is known that this kind of coating has a higher corrosion resistance and higher hardness ($H_{RC} > 52$).

2.3. Experimental apparatus

A pin-on-disc test machine, which has been described in detail previously [12], was used to investigate the friction and wear of UHMWPE in unidirectional sliding. The specimen geometry is shown in Fig. 1. The upper specimen (pin) was fixed and the lower specimen (disc) was rotated. The pins were of two kinds: UHMWPE and AISI52100 steel; the disc were of three types: UHMWPE, AISI1045 steel and UHMWPE coated with the Ni-P layer. The roughnesses were: UHMWPE (including pin and disc), $R_a = 0.5 \mu\text{m}$; AISI52100 steel pin, $1.0 \mu\text{m}$; AISI1045 steel disc, $0.8 \mu\text{m}$; UHMWPE, with a Ni-P layer $1.0 \mu\text{m}$.

3. Friction and wear tests

The friction and wear tests were carried out in three kinds of environments: a) air, room temperature ($\sim 25^\circ\text{C}$); b) vacuum ($6.67 \times 10^{-3} \text{ Pa}$), room temperature ($\sim 25^\circ\text{C}$); c) CO_2 saturation vapour, low

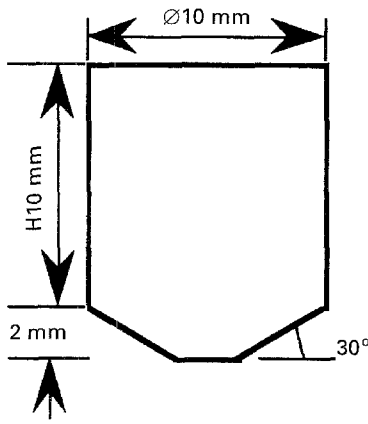

Figure 1 Schematic of specimen.

temperature ($\sim -20^\circ\text{C}$). The running-in distance was 15 m (at a sliding speed of $v = 0.25 \text{ m s}^{-1}$). The sliding friction coefficient μ versus sliding time t curves were measured with sampling frequency $f = 5 \text{ s}^{-1}$ from $t = 0 - 50 \text{ min}$, each point of μ was the average value of five measurements. In the plots of μ versus load P (v fixed) (Fig. 2) and μ versus v (P fixed) (Fig. 3), μ reached its average value after 10 min of the running-in period. Sticking occurred during the experiments for the UHMWPE-pin/UHMWPE-disc pair in CO_2 at low temperature, and thus there are no experimental points in Figs 2c and 3c for this experimental condition. The relative wear weight loss w_1 of the UHMWPE pin was determined based on the following expression

$$w_1 = \frac{w_0 - w_1}{w_0} \times 100\% \quad (1)$$

where w_0 is the original weight of the pin, w_1 is the weight of the pin after 1 h of the test. The details of the method were described in our previous paper, [12].

3.1. Variation of μ with P and v

Fig. 2 illustrates the curves of μ versus P at a constant speed (sliding speed $v = 0.25 \text{ m s}^{-1}$) for four rubbing pairs (p: pin; d: disc; PE: UHMWPE; Ni: Ni-P coating), which show that; (1) in air at room temperature (Fig. 2a), the value of μ of the PE-p/Ni-d pair increases slowly from 0.1 to 0.15; the value of μ of the PE-p/steel-d pair increases faster than that of the PE-p/Ni-d pair from 0.08 to 0.27 for the load $P = 1 - 20 \text{ N}$; the values of μ of the PE-p/PE-d and the steel-p/PE-d are almost the same, and increase even faster than the other two. (2) In vacuum ($6.67 \times 10^{-3} \text{ Pa}$) (Fig. 2b), the values of μ of all the four pairs are generally lower than those in air. The value of μ of the PE-p/Ni-d usually is the lowest at a comparable load P ; and the

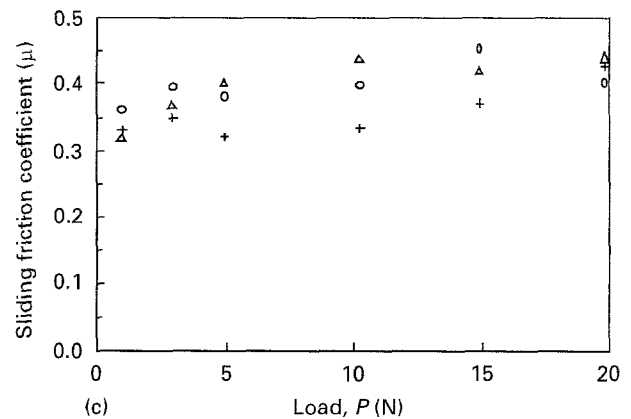
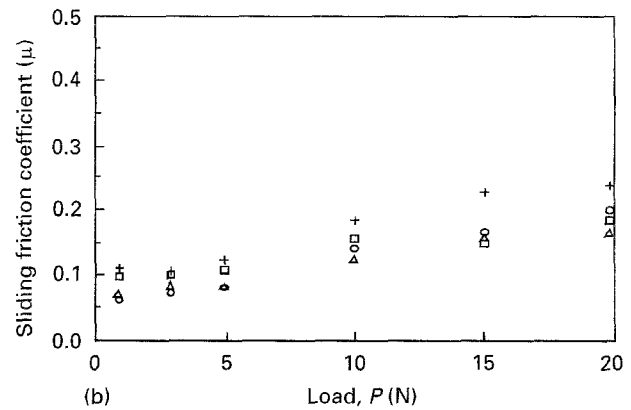
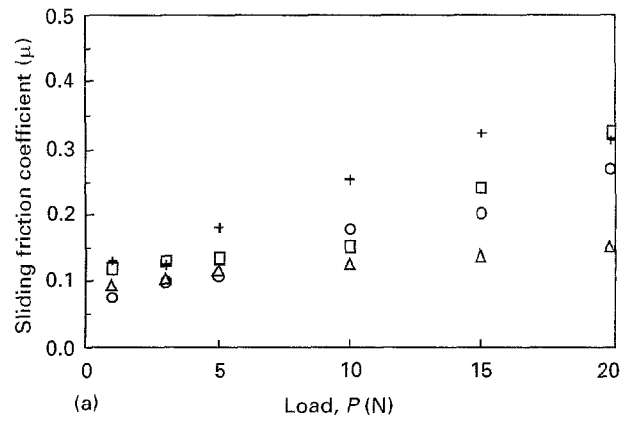

Figure 2 μ versus P curves ($v = 0.25 \text{ m s}^{-1}$, fixed). (a) In air, at room temperature; (b) in vacuum, at room temperature; (c) in CO_2 , at -20°C . In all cases the data were taken for the following pairs; (○) PE/steel, (△) PE/Ni-P, (□) PE/PE and (+) steel/PE.

value of μ of the steel-p/PE-d is the highest. (3) In CO_2 at low temperatures (Fig. 2c), the μ values of the measured pairs are above 0.3 and increase slowly from 0.3 - 0.35 to 0.4 - 0.45 except for the PE-p/PE-d pair for which no data could be collected due to sticking. Due to severe adhesion between the UHMWPE pin and the UHMWPE disc in CO_2 at low temperature, the sticking took place. As a result the sliding friction coefficient μ became very high and extremely unstable. Violent vibration of this specimen system was observed.

Fig. 3 shows the curves of μ versus v at a constant load ($P = 1.0 \text{ N}$) for all four of the rubbing pairs. It is found that: (1) In air (Fig. 3a), the values of μ increase slowly with an increase in v except the PE-p/PE-d pair. The slope of the μ versus v curve of the PE-p

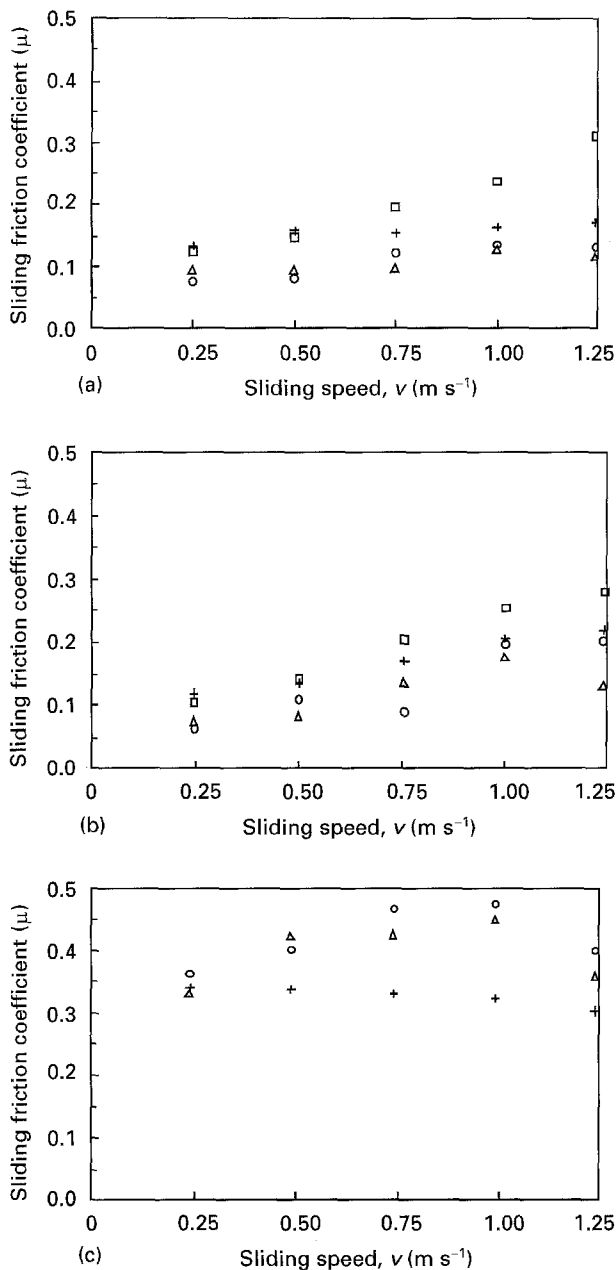

Figure 3 μ versus v curves ($P = 1.0$ N). (a) Air, room temperature; (b) vacuum, room temperature; (c) CO_2 , -20°C . In all cases the data were taken for the following pairs; (○) PE/steel, (Δ) PE/Ni-P, (□) PE/PE and (+) steel/PE.

/PE-d pair is steep. (2) In vacuum (Fig. 3b), the values of μ increase with v with almost the same slope as in the μ versus P (Fig. 2b) curve, only the absolute values of μ are different. The values of the PE-p/steel-d and PE-p/Ni-d pairs are lower than those of the PE-p/PE-d and steel-p/PE-d pairs. (3) In CO_2 at low temperature (Fig. 3c), the value of μ of the steel-p/PE-d pair decreases with an increase in v , but the values of the two other measured pairs (PE-p/Ni-d and PE-p/steel-d) increase slowly.

It is clear from Figs 2 and 3 that the Ni-P electroplated layer on the surface of the UHMWPE plays an important protective role when the frictional system operates in CO_2 at low temperature. There are two reasons that account for the significant increase of adhesion between UHMWPE surfaces: one is that CO_2 promotes an increase in the molecular force

TABLE 1 Relative wear of UHMWPE Pin (PE-p)

(a) in air at room temperature

P (N)	v (m s^{-1})	PE-p/Steel-d	PE-p/Ni-d	PE-p/PE-d
1.0	0.25	1.2	4.5	-4.4
3.0	0.25	9.5	1.6	8.1
5.0	0.25	3.0	2.5	-8.9
10	0.25	0.71	4.1	19.1
15	0.25	5.2	4.8	4.6
20	0.25	8.8	5.3	0.75
1.0	0.50	9.8	0.81	-5.6
1.0	0.75	1.3	4.4	6.7
1.0	1.00	7.0	0.70	-10.7
1.0	1.25	8.9	8.1	8.9

(b) in vacuum at room temperature

P (N)	v (m s^{-1})	PE-p/Steel-d	PE-p/Ni-d	PE-p/PE-d
1.0	0.25	2.8	4.5	-0.92
3.0	0.25	6.4	1.8	-5.3
5.0	0.25	0.93	0.25	11.2
10	0.25	0.66	4.1	4.7
15	0.25	10.3	1.6	-0.77
20	0.25	4.2	3.5	-11.3
1.0	0.50	2.9	0.44	-7.5
1.0	0.75	0.67	3.2	3.2
1.0	1.00	4.7	4.1	-2.8
1.0	1.25	0.90	0.68	5.8

Counterparts: Steel-disc, Ni-disc and PE-disc.

Wear data w_t in [10^{-3}].

between the two UHMWPE surfaces; another is that molecular movement is more difficult at low temperature than at room temperature.

3.2. Variation of w_t

The relative weight losses of worn UHMWPE pins were measured for the three rubbing pairs: PE-p/PE-d, PE-p/Ni-d and PE-p/steel-d and are listed in Table 1 which shows that the range of the values of w_t is about $\pm(10^{-1}-10^{-2})$. In the case of the PE-p/steel-d pair, the value of w_t was greater than that of the PE-p/Ni-d. It is known that UHMWPE is transferred more seriously in the former case than for the latter case. For the PE-p/PE-d pair, the majority of w_t values were positive, however a few negative values were recorded. The absolute value depends on the surface roughness and the experimental conditions. It is clear that there was mutual transfer of matter, and that the material transfer from pin to disc was often easier than the reverse case. Due to the UHMWPE transfer film formed on the worn surface of the steel pin, the value of w_t was always negative for the steel-p/PE-d pair. Since the steel pin was much heavier than the UHMWPE pin, the values of w_t for the steel pin and the UHMWPE pin could not be compared with each other. Actually this measurement is not accurate enough because the variation in the weight of the UHMWPE pin was affected by many factors. A change in humidity or CO_2 saturation vapour in the environment can cause variation in the value of w_t .

4. TEM and SEM observations

4.1. TEM observation of worn pin surfaces

A replica specimen of the surface worn pin was prepared for the transmission electron microscope (TEM) observations. Figs 4 and 5 show the wear track of the worn UHMWPE pin against the UHMWPE disc (Fig. 4) and the Ni-P electro-plated UHMWPE disc in CO₂ at a low temperature (Fig. 5). It shows that: (1) The worn surface of the UHMWPE pin sliding against the UHMWPE disc (Fig. 4) has a torn morphology. There are many deep cracks, sheet-like hollows and big and/or small aggregates on the surface. (2) As the load P and sliding speed v increase the worn surface becomes rougher, the worn surface for a pin at $P = 20$ N and $v = 1.25$ m s⁻¹ (Fig. 4d) attracts many aggregates. Thus, the cracks are deeper than those at $P = 1$ N and $v = 0.25$ m s⁻¹ (Fig. 4a). (3) There are many parallel stripes on the worn surface of the UHMWPE pin sliding against the Ni-P electro-plating (Fig. 5(a-d)). (4) The worn pin obtained at $P = 1$ N and $v = 0.25$ m s⁻¹ has shallow parallel stripes (Fig. 5a) and the stripes on the surface of the worn pin obtained at $P = 1$ N and $v = 1.25$ m s⁻¹ (Fig. 5b) are

slightly deeper than the former. On the contrary, the stripes on the surface obtained at $P = 20$ N and $v = 0.25$ m s⁻¹ (Fig. 5c) are much deeper than the two others. (5) For the specimen produced at $P = 20$ N and $v = 1.25$ m s⁻¹ (Fig. 5d) there are two kinds of stripes. Most of them are shallow, however a few are much deeper.

4.2. SEM observation of wear debris

Figs 6 and 7 show the wear debris collected from the PE-p/PE-d and the PE-p/Ni-d rubbing pairs. Sheet-like wear debris are found in the PE-p/PE-d pair (Fig. 6) but rope-like wear debris are found in the PE-p/Ni-d pair (Fig. 7). The wear debris in Fig. 6 came from the worn surface exposed in Fig. 4 and those in Fig. 7 came from that in Fig. 5. It is found that there are two different wear mechanisms. Adhesive wear occurs in the PE-p/PE-d pair, and fatigue wear in the PE-p/Ni-d pair. It was also found in the SEM observations that there are non-continuous transfer films on the steel and the Ni-P surfaces.

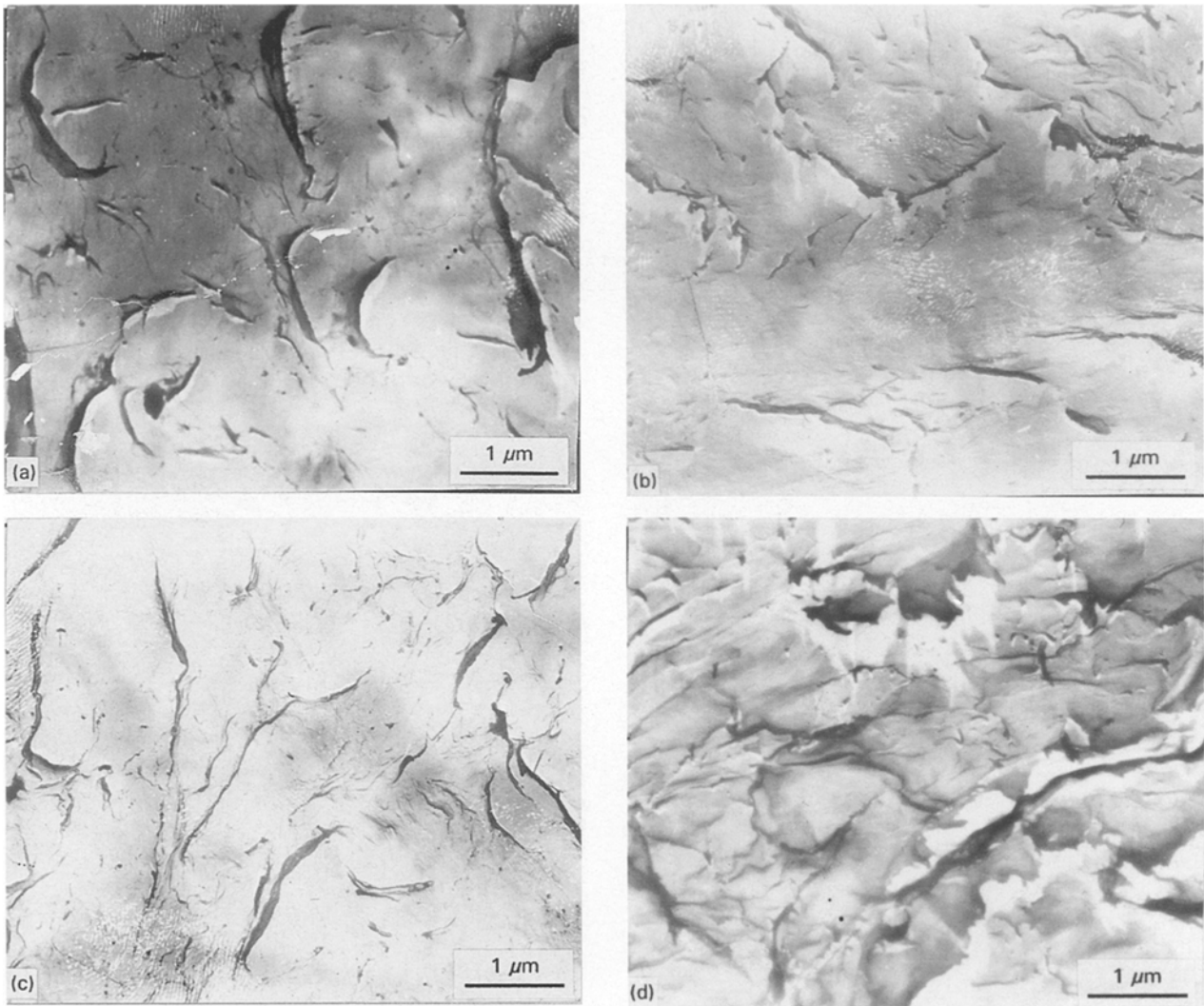

Figure 4 TEM observation of worn UHMWPE pin surface sliding against UHMWPE disc. (a) $P = 1.0$ N, $v = 0.25$ m s⁻¹; (b) $P = 1.0$ N, $v = 1.25$ m s⁻¹; (c) $P = 20$ N, $v = 0.25$ m s⁻¹; (d) $P = 20$ N, $v = 1.25$ m s⁻¹.

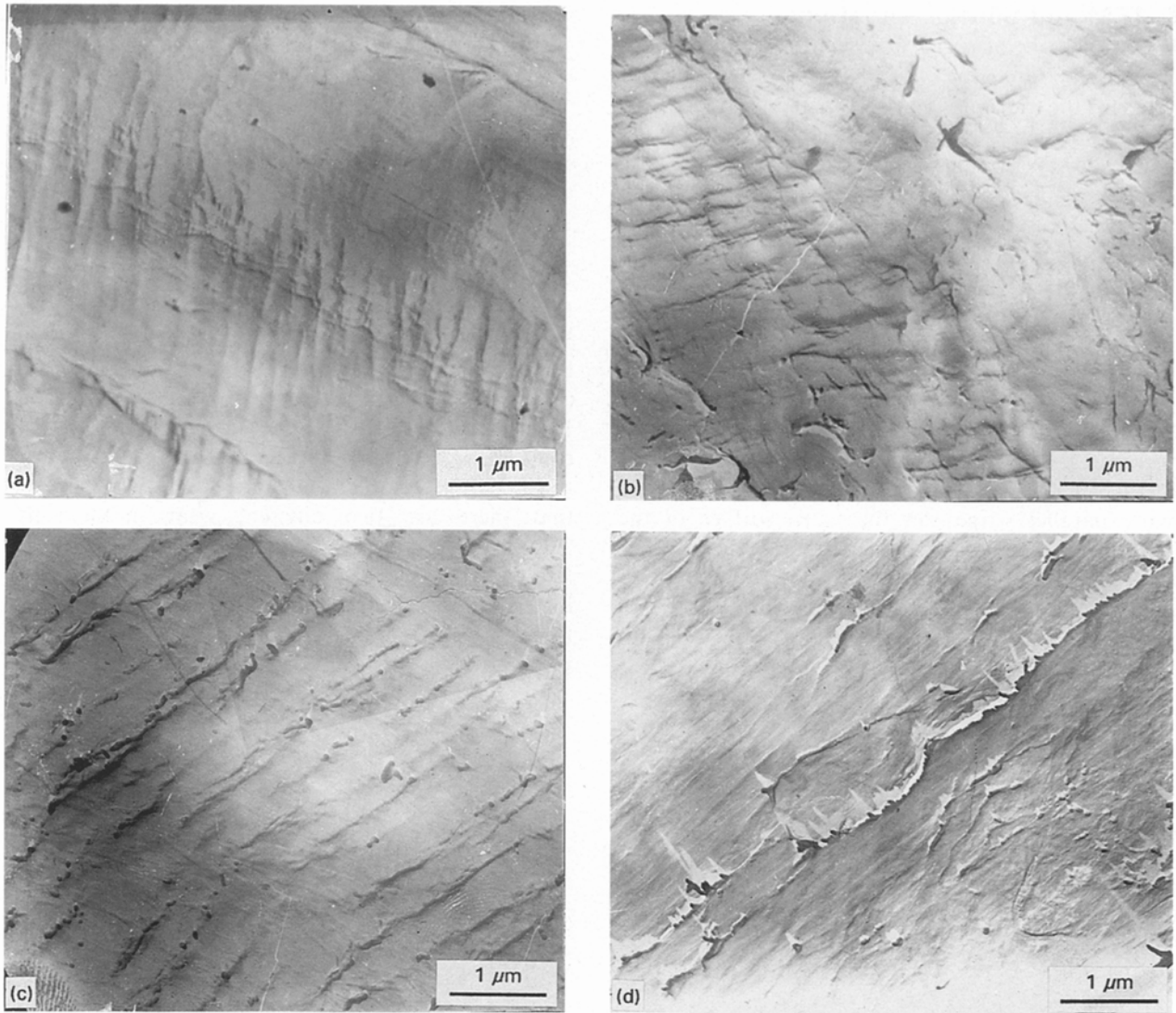

Figure 5 TEM observation of worn UHMWPE pin surface sliding against an Ni-P covered UHMWPE disc. (a) $P = 1.0 \text{ N}$, $v = 0.25 \text{ m s}^{-1}$; (b) $P = 1.0 \text{ N}$, $v = 1.25 \text{ m s}^{-1}$; (c) $P = 20 \text{ N}$, $v = 0.25 \text{ m s}^{-1}$; (d) $P = 20 \text{ N}$, $v = 1.25 \text{ m s}^{-1}$.

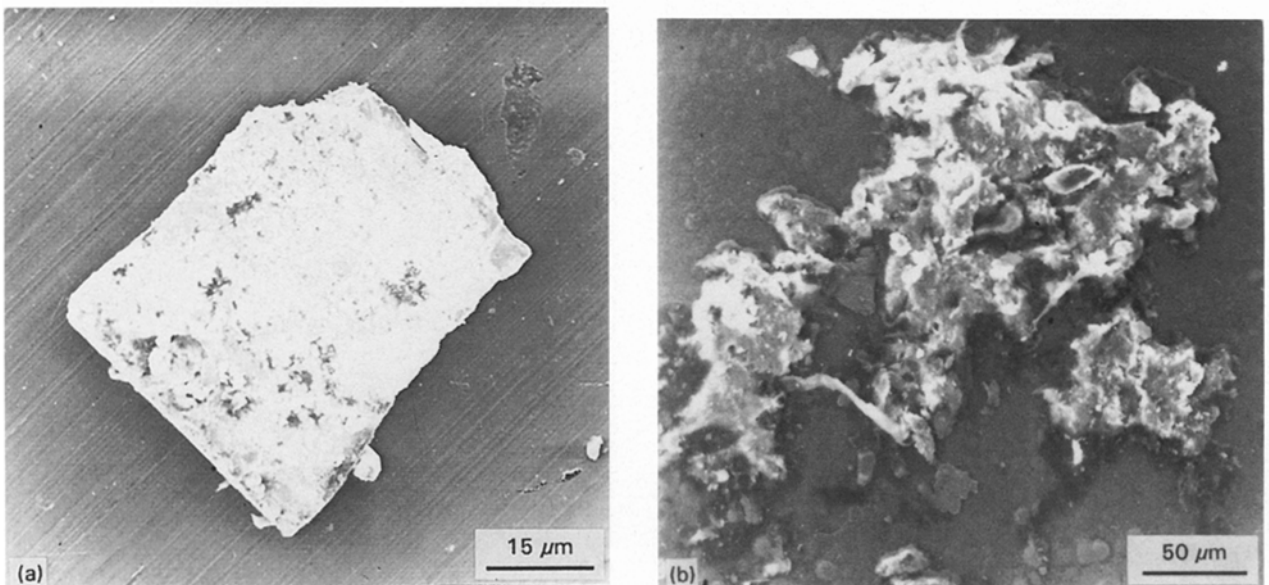

Figure 6 SEM observation of wear debris for UHMWPE pin sliding against UHMWPE disc. (a) $P = 1.0 \text{ N}$, $v = 0.25 \text{ m s}^{-1}$; (b) $P = 20 \text{ N}$, $v = 0.25 \text{ m s}^{-1}$.

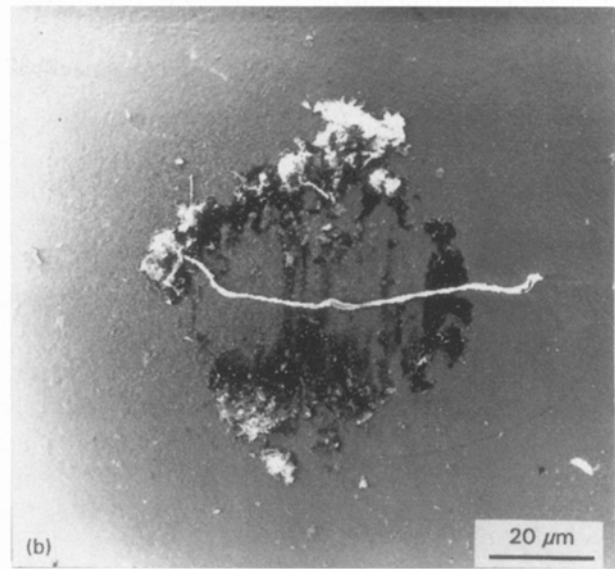
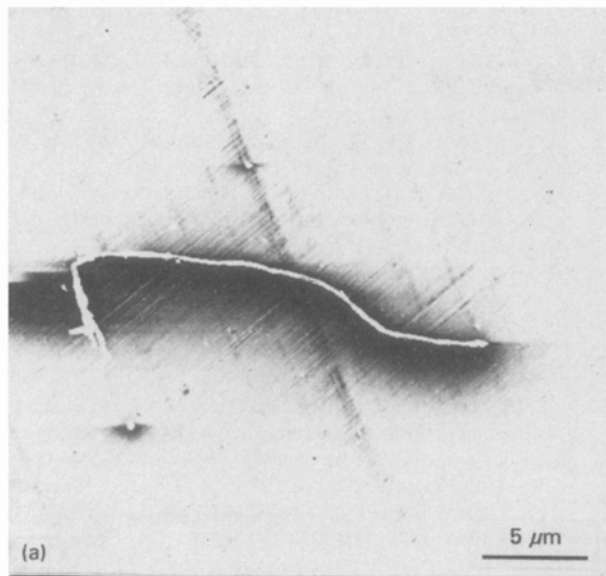

Figure 7 SEM observation of wear debris for UHMWPE pin sliding against a Ni-P covered UHMWPE disc. (a) $P = 1.0 \text{ N}$, $v = 0.25 \text{ m s}^{-1}$; (b) $P = 20 \text{ N}$, $v = 0.25 \text{ m s}^{-1}$.

5. Discussion

5.1. The transfer film of UHMWPE

The transfer behaviour and its effect on the tribological performance of the UHMWPE are important problems for industrial applications of UHMWPE. In our experiments, a non-continuous transfer film of UHMWPE is formed. The occurrence of this film significantly influences the values of the sliding friction coefficient μ and the relative wear weight loss of the worn pin w_t . There is a close correlation between the roughness of the specimen and the tribological behaviour [1, 13, 14]. Owing to the discontinuity of the polymer transfer film, there is no obvious relationship between the intrinsic properties of materials and the tribological behaviour parameters [15]. The factors which influence the formation of the UHMWPE transfer film as well as the interaction between the transfer film and the substrates must be further explored.

5.2. Wear mechanisms of UHMWPE/Ni-P and UHMWPE/UHMWPE pairs

There are many discussions on the wear mechanisms of polymer materials [15–18]. It is shown that when stable friction films are readily formed for a given rubbing pair, a stable friction level and a low wear rate can be maintained. In our experiments, this stable film was not formed, even for the PE-p/steel-d and the PE-p/Ni-d pairs. Thus fatigue wear occurred at room temperature and low temperature, in air, vacuum and a CO_2 saturation vapour. Due to this fatigue wear, the stripe-like tracks on the UHMWPE worn surface and the rope-like wear debris of the UHMWPE formed. For the PE-p/PE-d pair, the situation is rather complicated. Stable sliding wear occurred for this rubbing pair at room temperature in air and vacuum at $P = 1 - 20 \text{ N}$ and $v = 0.25 - 1.25 \text{ m s}^{-1}$, but sticking occurred at low temperature ($\sim -20^\circ\text{C}$) in the CO_2

saturated vapour. The wear mode is always adhesive wear under the current experimental conditions. The identification of adhesive wear is underpinned by the formation of the torn morphology on the worn surface of the UHMWPE and the sheet-like wear debris. Sticking can produce significant damage in moving parts in a machine, and thus it must be avoided. A protective coating on the surface of the UHMWPE should be an effective way to reduce stick-slip. In this paper, we suggested a Ni-P electroplated layer covering the surface of the UHMWPE. The UHMWPE covered with the Ni-P layer, on one hand, retains some of the properties of a thermoplastic polymer; on the other hand, the tribological behaviour of this material is improved, especially in the CO_2 vapour at low temperature. The experimental results show that it is a successful method.

6. Conclusions

- (1) The UHMWPE slid against steel and the Ni-P electro-plated coating have a low relative wear weight loss w_t and moderate sliding friction coefficient μ . Generally they have their lowest values in vacuum at room temperature, and their highest values in CO_2 saturated vapour at low temperature.
- (2) If the UHMWPE slides against itself, sticking occurs in CO_2 at low temperature. A Ni-P electro-plating layer can improve the tribological properties of the UHMWPE under some extreme working conditions.
- (3) The wear mechanism is fatigue wear for the PE-p/Ni-d, PE-p/steel-d and steel-p/PE-d rubbing pairs. The wear track on the surface of the UHMWPE is stripe-like whilst the wear debris are rope-like.
- (4) The wear mechanism is adhesive wear for the PE-p/PE-d pair. The wear track has torn morphology and the wear debris are sheet-like. The difference in wear mechanisms determines the difference of the tribological behaviour amongst the four rubbing pairs.

The Ni-P coating on the UHMWPE significantly improves the tribological behaviour for the UHMWPE disc sliding against a fixed pin, especially in vacuum at low temperature. In space, many machine parts operate under similar working conditions. UHMWPE is used in many machine parts, such as bearings, because it has good self-sealing and self-lubricating properties and a light weight. Unfortunately its mechanical properties, such as toughness, stiffness and strength, degrade at low temperature. In vacuum, if the UHMWPE slides against itself, severe adhesive wear could take place. Thus the Ni-P coating is very useful for protecting the surface of the UHMWPE, due to its excellent tribological behaviour and good mechanical properties. Further investigations on the use of Ni-P protective coatings on UHMWPE would be of considerable interest.

Acknowledgements

The authors acknowledge the help of Professor K. Friedrich, and record thanks to the D. F. G. for sponsoring this research. We are also indebted to Ms. Wang Caifeng, Mr. Xia Weimin and Ms. Ma Xiaohua, Tsinghua University, P.R. China, for TEM and SEM investigations.

References

1. A. I. G. ILOYD and R. E. J. NOEL, *Tribol. Int.* **21** (1988) 83.
2. T. A. BLANCHETT and F. E. KENNEDY, *Tribol. Trans.* **32** (1989) 371.
3. J. R. ATKINSON, K. J. BROWN and D. DOWSON, *J. Lubr. Technol.* **100** (1978) 208.
4. *idem, ibid* **104** (1982) 17.
5. T. S. BARRETT, G. W. STACHOWIAK and A. W. BATCHELOR, *Wear* **153** (1992) 331.
6. QUNJI XUE, XIAOYAN YU, TONGSHENG LI and HONGXIN DANG, in Proc. Intern. Symp. on Tribochemistry, Lanzhou, China, 25-28 Aug., (1989), 227-51.
7. K. MARCUS, A. BALL and C. ALLEN, *Wear* **151** (1991) 323.
8. J. C. ANDERSON, *Tribol. Int.* **15** (1982) 43.
9. J. H. DUMBLETON and C. SHEN, *Wear* **37** (1976) 279.
10. G. C. RUBEN, T. A. BLANCHETT and F. E. KENNEDY, *J. Mater. Sci.* **28** (1993) 1045.
11. RENJI ZHANG, in Proc. The 3rd Intern. Conf. on Advances in Coatings and Surface Engineering for Corrosion and Wear Resistance and Other Applications, Newcastle upon Tyne, UK, 11-15 May, (1992).
12. RENJI ZHANG, ZIWEI LIN, ZHOUPING CUI and QI SONG, *Wear* **147** (1991) 227.
13. P. M. DICKENS, J. L. SULLIVIAN and J. K. LANCAS-TER, *ibid* **112** (1986) 273.
14. J. SONG and G. W. EHRENSTEIN in "Advances in Composite Tribology" edited by K. Friedrich (Elsevier, Amsterdam, 1993) pp 19-64.
15. G. ERHARD, *Wear* **84** (1983) 167.
16. M. G. JACKO, P. H. TSANG and S. K. RHEE *ibid* **133** (1989) 23.
17. J. M. THORP, in "Friction and Wear of Polymer Composite", edited by K. Friedrich, (Elsevier, Amsterdam, 1986), pp 86-136.
18. J. C. ANDERSON, *ibid* pp 329-62.

*Received 30th March 1995
and accepted 18th March 1996*